



भारतीय राष्ट्रीय राजमार्ग प्राधिकरण

(सड़क परिवहन और राजमार्ग मंत्रालय)

National Highways Authority of India

(Ministry of Road Transport and Highways)

जी-5 एवं 6, सेक्टर-10, द्वारका, नई दिल्ली-110075

G-5 & 6, Sector-10, Dwarka, New Delhi-110075

दूरभाष / Phone : 91-11-25074100/25074200

फैक्स / Fax : 91-11-25093507 / 25093514

NHAI/Policy Guidelines/ Strengthening the Incident Management services/2018
Policy No.12.19, Dated the 20th March 2018
(Decision taken in 337th meeting of the Executive Committee under Agenda No.337.08
& Chairman approval on 20.03.2018)

Sub: Strengthening the Incident Management services being provided across existing concessions and on not covered stretches.

NHAI is constructing/ upgrading National Highways across the country on EPC/HAM/BOT mode from 2/ 4 lanes to 4/6 lanes and developing various expressways to facilitate for smooth and safe travel of road users. For efficient functioning of 4/6 lane National Highways, Operation & Maintenance activities are to be taken up simultaneously for safety of road users for which, Incident Management vehicles such as Ambulances, and Patrol vehicles duly fitted with GPS/ VTS system are to be deployed.

2. Currently, Incident Management services (ambulances and patrol vehicles) are provided primarily on completed highway stretches which are under BOT or OMT concessions, totalling to approximately 10,000 km.

3. It has been observed that there is a large variation in the quality of service and standards of ambulances and patrol vehicles currently deployed across various concessionaires / contractors, primarily because the concessions / contracts have been awarded at different points in time. Further, each highway concessionaire operates a local control room with an independent helpline number.

4. The proposal was discussed in the EC-337th meeting held on 05.03.2018 and the following decisions were taken :-

(a) The system in the existing concessions may be strengthened by ensuring uniformity of the standards for ambulances and patrol vehicles and

(b) Engaging such facilities at every 50 km in stretches where works is in progress. All these facilities shall be integrated with the helpline No. 1033. Hence, all incident related calls shall be directed to this helpline number, and shall be subsequently re-directed to the local control room of the respective concessionaire for incident management.

5. Accordingly the following executive directions are issued:-

(a) Uniform specifications along with new colour scheme of Ambulance and Patrol Vehicle duly approved by the competent authority are enclosed as **Annexure-I** for strict implementation.

(b) The existing Ambulances services and Patrol vehicles under BOT and OMT and other existing contracts needs to be upgraded and strengthened up to the above standards and specifications within next 3 months time. The strengthening of system will be done by respective concessioner/contractor with the guidance of ROs under change of scope. Last date of completion of upgradation/strengthening work is 30.06.2018.

4

(2)

(c) The similar facilities are to be provided @ 50 km on the other stretches of National Highways which are completed and are under maintenance of the construction agency by providing them a change of scope for which ROs are authorised.

(d) On the stretches of National Highways which are under construction/Under Implementation/widening and where, no such facility exist in the concession/contract agreement, similar facility will be provided by providing the Change of Scope to the construction agency for which ROs are authorised.

(e) For all other stretches, which are under Operation & Maintenance by O&M agencies and no such facility exist in their contract agreement. The similar facilities to be provided @ 50 km by the O&M Agency by providing them a change of scope for which RO are authorised.

(f) The new facility to be provided strictly as per the specifications and colour schemes given in **Annexure-I** by the ROs under OPEX or Service Model/Rent basis contract usually made for 2 years.

6. These facilities must be deployed and made operational on all the stretches as directed above by 30th June, 2018 without fail.

7. This is issued with the approval of the Competent Authority (Ref. EC Agenda 337.08)

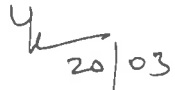
20/03
(V.K. Sharma)

Chief General Manager (Coord.)

Encl: (Annexure-I) As above

To

1. All Officers at NHAI HQ/ROs/PIUs/CMUs/Site Offices
2. To PS of Chairman and all Members for information
3. For hosting on NHAI Website
4. Hindi Officer for translation in Hindi

'2 patient capacity' Rescue Ambulance Specifications

Every '2 patient capacity' rescue ambulance should adhere to the minimum specifications as described below:

Vehicle Characteristics

General Construction

- The road rescue ambulance shall comply with homologation requirements given in standards notified under CMVR 1989 and the AIS-125 Code. Wherever, there is difference in the homologation requirements given in other standards notified under CMVR 1989 and AIS-125 code, the requirements of AIS-125 code will be applicable.
- The rescue ambulance vehicle shall be a Swaraj Mazda/ Tempo traveler or equivalent which should be a new vehicle and should not have covered more than 2000 km at the time of procurement (from date of first registration)

Performance Requirements

- The road rescue ambulance loaded to the permissible gross vehicle weight shall be able to accelerate from 0 km/h to 70 km/h within 40s, when tested in accordance with IS: 11851-1986.

Electrical Requirements

- **General**
 - Electrical installations shall comply with those Clauses of IEC 60364-7-708 which are applicable to rescue ambulances.
- **Battery and alternator**
 - Batteries shall be positioned to allow maintenance without removing the battery from its securing device. The construction of the battery and all connections to it shall be such as to prevent any possibility of an inadvertent short circuit. Additional batteries may be required to power the medical devices carried on board and the intended use of the rescue ambulance. In such cases, the manufacturer shall ensure optimal charging of the additional batteries without any impact on the primary vehicle battery. The additional circuit shall not draw current more that specified by the manufacturer.
 - Indicative Capacity / Power (These values are given as a broad guideline only. The manufacturers may alter them based on vehicle characteristics and operational requirements) should be as per the below mentioned table



Indicative capacity/ power requirements		
Additional Battery(ies) (if deployed)	Nominal Voltage 12V	80Ah
	Nominal Voltage 24V	63Ah (2x12V)
Alternator Power		700W

- When the engine is idling, electrical stability should be maintained between electrical load and alternator output. In order to achieve this it may be necessary to fit an electrical load prioritization device to the vehicle.
- Manufacturer shall give declaration regarding the certified capacity of the electric system of the vehicle model in the following format:

Sr.No.	Rescue Ambulance Type	Additional Electric Load of Medical Equipment's permissible (Watts)
1	C/ Basic Life Support	XXX

- This shall be prominently displayed in the patient compartment at an appropriate location. Further each electrical socket provided in the patient compartment should be permanently labelled as regards its voltage and amperage.
- **Electrical installation**
 - Recessed externally mounted power connector to enable external power to be provided for operations such as the following:
 - a) Charging battery (ies).
 - b) Operating medical devices, when installed.
 - c) Operating a stand-alone patient compartment heater, when installed.
 - d) Operating an engine pre-heater, when installed.
 - The connector for 220/240 V, shall be a male connector and not interfere with the electrical and mechanical safety.
 - It shall be not possible to start the engine whilst it is connected to an external 220/240 V power supply unless an automatic mechanical disconnection is fitted. If no automatic mechanical disconnection is fitted, the connector shall be on the driver's side. The 220/240 V circuit shall be protected either by an "earth leakage device" with a maximum setting of 30 mA or by a separate transformer. If the protection is given only by an "earth leakage device" there shall be a label near the plug that reads as follows: "CAUTION! CONNECT ONLY TO AN AUTHORISED SOCKET."



- The patient's compartment shall be fitted with a minimum 4 number of connections. For these connections a permanent power supply shall exist.
- Any additional electrical systems fitted to the base vehicle shall be separate from the base vehicle electrical system and the body or chassis shall not be used as an earth return for additional circuits. All circuits in the additional system(s) shall have separate overload protection. Overload protection may consist of either fuses or so called Electronic Management Control systems. All circuits shall be well defined and cables clearly marked at the connection points and at a maximum of 1m intervals along its length.
- The system shall have enough circuits and be so constructed that when/if a circuit fails all illumination and medical technical equipment can be switched to an alternative power source.
- The wiring and, where applicable conduits, shall withstand vibrations. No wiring shall be located in or pass through conduit intended for medical gas installation. The wiring shall not be loaded higher than that stated by the wire manufacture.
- Where there are different voltage systems, the connections shall be non- interchangeable.

Vehicle Body

- **Fire safety**
 - All interior materials shall comply with the flammability requirements specified in IS: 15061, as notified under CMV (A) R, 1989 though the standard does not cover rescue ambulance in the scope.
- **Fitment of fire extinguisher**
 - The rescue ambulance shall be equipped with Two fire extinguishers of 2 Kg each.
- **Minimum loading capacity**
 - The minimum loading capacity of at least 2 stretcher facilities in the patient compartment. Serious casualties/ patients must not be transported on patient compartment seat without use of stretcher & proper restraining support provided to the patient.
- **Partition wall**
 - Full partition wall or a partition wall with a door or a window shall separate the driver's compartment from the patient's compartment. Where a door is fitted, it shall be secured against opening if the road rescue ambulance is in motion.



- One or two windows with a minimum separation of 100 mm shall be provided in the partition wall made of material complying with the requirements of CMVR. The windows shall allow direct visual contact with the driver. The opening area of the window shall have a maximum area of 0,12 m². It shall be secured against self-opening and shall have an adjustable blind or other means of preventing the driver being disturbed by the light of the patient's compartment.
- **Openings (Doors, Windows, Emergency Exits)**
 - General
 - a) The driver seat shall comply with the requirements of AIS-023:2005 or IS:15546-2005 as applicable and notified under CMVR. There shall be a minimum of two openings - one at the rear (door/tailgate) and one at the side (door/window) of the patient's compartment. All openings shall have seals to protect against the ingress of water and dust.
 - b) All openings shall comply with the minimum dimensions set out in the following table

		Dimensions in mm
Side Opening (Optional)	Height	1300
	Width	660
Rear Opening	Height	1300
	Width	1050

- **Doors**
 - a) Each external door of the patient's compartment shall be fitted with a security system which enables the following:
 - lock and unlock from inside without use of a key
 - lock and unlock from outside with use of a key
 - Unlock from the outside using a key when the door is locked from the inside.
 - b) **Note:** This security system may be integrated with an optional central locking system. The patient's compartment doors shall be capable of being positively restrained in the open position.



An audible or visual signal shall warn the driver when any door is not completely closed when the vehicle is in motion. The key can be a mechanical or non-mechanical device.

– Windows

- a) In the patient's compartment, there shall be a minimum of two external windows. There shall be one on each side or one on the side and other at the rear. The windows shall be positioned or screened to ensure patient's privacy when required. Windows shall be fitted with safety glasses complying with the requirements of IS:2553 specified under Rule 100 of CMV(A)R, 1989.

– Stretcher loading

- a) Loading area requirements shall be in accordance with the following table.

Loading Angle (Stretcher)	Maximum	160 a
Loading Height (Stretcher)	When the patient is manually loaded or unloaded on the stretcher, the centre of the stretcher handles shall be no more than 975 mm above ground level. The maximum height of either the floor or the loading holding assembly above ground level shall not exceed 900 mm at net vehicle mass plus loose equipment.	
The loading angle should be kept as low as possible		

- b) Where a ramp or lift is installed between ground level and vehicle floor level it shall be covered with a anti-slip surface and capable of taking a constant load of 350 kg. In the event of a power failure the loading device shall be capable of being operated manually.
- 

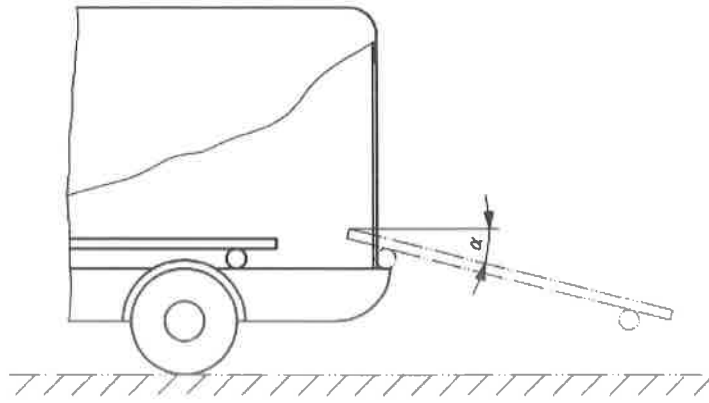

Figure 1: Loading angle for the stretcher

Patient's Compartment

- **General**

- The patient compartment should have minimum internal dimensions of at least 2500 mm (length) x 1800 mm (width) x 1800 mm (height).
- The patient's compartment shall be designed and constructed to accommodate the medical devices listed in the equipment table. The width of the patient compartment after installation of cabinets, etc. shall provide 40 ± 15 cm clear aisle walkway between the main stretcher / undercarriage and the base of squad bench / attendant seats, with the main stretcher located in the street side (non-centered) position.
- The length of the Patient Compartment shall provide at least 64 cm and not more than 76 cm of unobstructed space at the head of the primary patient, when measured from the face of the backrest of the Doctor's/Paramedic's Seat to the forward edge of the stretcher.
- The ceiling, the interior side walls and the doors of the patient's compartment shall be lined with a material that is non-permeable and resistant to disinfectant. The edges of surfaces shall be designed and/or sealed in such a way that no fluid can infiltrate. If the floor arrangement does not allow fluids to flow away, one or more drain with plugs shall be provided. Exposed edges that could come into contact with the occupant's hands, legs, head etc., during normal use shall have a radius of curvature of not less than 2.5 mm except in the case of projections of less than 3.2 mm, measured from the panel. In this case, the minimum radius of curvature shall not apply provided the height of the projection is not more than half its width and its edges are blunted. All installations in the patient compartment above 700 mm from floor level shall not have sharp exposed edges and shall terminate in rounded edges. Sharp edges shall meet the requirements of IS 15223 for M1 and AIS-047 for M2



as amended from time to time. Medical equipment and their holding devices (for example stretchers, platforms, suction units etc.) are excluded. Drawers should be secured against self-opening and where lockers are fitted with doors that open upwards they should be fitted with a positive hold open mechanism.

- The rescue ambulance should be equipped with a lockable drugs compartment with security lock. Floor coverings shall be chosen that will provide adequate grip for the attendant including when wet and should be durable and easy to clean.
- The rescue ambulance should also be fitted with a hand-holding device positioned above the stretcher. The hand-holding device shall be positioned along the longitudinal axis. If the patient's compartment is to be equipped with a non-foldable chair, space shall be provided with a width of at least 600 mm measured at elbow height and a ceiling height above the seat squab of at least 920 mm. Vehicle maintenance equipment (e.g. Spare wheel and Tools) shall be placed such that accessing them does not cause inconvenience to the patient

- **Patient and attendant seating**

- The minimum number of patient and attendant seats should be as per the following table:

Minimum number		2
Position (s)	on one side of the stretcher	1
	on one side of the stretcher upper 2/3 end	1
Position(s) at head of stretcher		-

- **Patient and attendant seat dimensions**

- Patient and attendant seat dimensions shall be minimum of 381 mm X 381 mm per seat. Seats fitted in the patient compartment shall be installed in either forward / sideward / rear-facing positions and shall be fitted with Two Point (Lap Belt) or Three Point Retractable Safety Belts (preferred for forward / rearward facing seats) in conformance with IS:15140-2003. Head restraints shall be fitted as applicable and in accordance with AIS-023:2005 or IS: 15546-2005. Backrests shall be constructed to a minimum dimension of 300 mm × 100 mm.

- **Patient compartment environmental equipment**



- The patient compartment shall be heated, ventilated, and air conditioned as required in accordance with the criteria specified hereto.
- **Air conditioning criteria**
 - The cooling system should be such that, given an outside and inside temperature of 32 °C, the cooling down to at most 27 °C in the patient's compartment should not take longer than 15 min. After 30 min a temperature of at most 25 °C should be reached.
 - The inside temperature should be measured in the centre of the patient compartment and at the mid-point from the cooling outlets (if several outlets are available). The installation of the system shall not encourage exhaust gases entering the patient's compartment.
- **Heating**
 - If the heating system is provided, the system shall be such that given an outside and inside temperature of -10 °C, the heating up to at least +15 °C shall not take longer than 45 min. The inside temperature shall be measured in the centre of the patient compartment and at the midpoint from the heater outlets (if several outlets are available). The installation of the system shall not encourage exhaust gases entering the patient's compartment.
- **Interior lighting**
 - Natural colour balance lighting shall be provided as set out in the table below.
 - **Note:** The colour temperature of the light will change the appearance of skin and organs. Therefore it is important that the interior lighting is suitable for patient care during transport. Although it may not be necessary in rescue ambulance use to define "daylight" or "natural colour balance" in a more exact way other than the colour temperature. The colour temperature of the interior lights should be minimum 4000 Degrees Kelvin.

Patient's compartment illumination - Minimum intensity Lux	
Patient Area (Stretcher)	150
Surrounding Area	50

- Light levels shall be measured along the central longitudinal axis of the stretcher at the head, mid-point and foot position with the stretcher in its normal position for transportation in the rescue ambulance.
- **Interior noise level**
 - The interior noise level in the patient compartment shall comply with requirements of AIS-020. During the test, the Siren of the rescue ambulance shall be kept in the Off position.



- **Ingress of dust and rain water**
 - All doors, windows and hatches shall not allow ingress of dust and rain water when in the fully closed position, when tested in accordance to IS : 11739 - 1986 as amended from time to time, for recording dust ingress in automotive vehicles, and when tested in accordance to IS: 11865 - 2006 as amended from time to time, for water proofing test for automobiles.
- **Mounting systems**
 - Permanent seats and their anchorages in the patients' compartment, designed for use by patients and attendants when the rescue ambulance is in motion, shall comply with the requirements of IS 15546:2005 (for M1 category vehicles) and AIS-023 :2005 (for other than M1 category vehicles).
 - All items e.g. medical devices, equipment and objects normally carried on the road rescue ambulance shall be restrained, installed or stowed to prevent them becoming a projectile when subjected to accelerations/decelerations of 10 g in the forward and rearward directions.
 - When subjected to these accelerations/decelerations, the distance travelled by an equipment or an item shall not endanger the safety of persons on the road rescue ambulance.
 - After being subjected to these accelerations/decelerations:
 - a) no items shall have sharp edges or endanger the safety of persons in the road rescue ambulance;
 - b) the maximum distance the stretcher and any item attached to either the holding assembly or stretcher may travel shall be no more than 150 mm. The displacement of the patient during the test may exceed 150 mm;
 - c) it shall be possible to release all persons in the road rescue ambulance without the use of equipment not carried on the road rescue ambulance.
 - All tested lockers, rails and non-dedicated storage locations or storage devices shall be labelled to show the total maximum permissible weight allowed.

Testing of Maintain Systems and Fixations of the equipment in the Patient's Compartment



- Verification of conformity to fixation and maintain systems shall be made when the stretcher(s) / medical device(s) and holding assembly is placed in the mean position of all possible positions available.
- The sample submitted for test, shall be identical to or have the same characteristics and behaviour during test as would the production item or vehicle. Note: Care should be taken that no internal / external additional reinforcement through the rig will modify the behaviour during test.
- The stretchers and chairs shall be loaded with a dummy (as specified in IS 15140 :2003) which is then secured with the restraint system.
- The head end of the stretcher shall be fixed in a position of 15° measured from the horizontal. The lying area of the stretcher tray assembly (holding assembly) shall be in a horizontal position.
- The stretcher shall be fixed on the stretcher's holding assembly. The sedan chair when provided shall also be fixed in its holder.
- The dynamic tests can be carried out with the appropriate stretcher(s) or medical device(s) installed or stowed in the holding system(s) or with weights having the mass distribution and dimensions corresponding to the mass and dimensions of the stretcher(s) and device(s) intended to be installed on or stowed in the holding system.
- In case of dynamic testing, the dynamic test shall be carried out using a patient's compartment assembly or a relevant part of the construction approved by the notified body and the following test method:
 - The test assembly shall be accelerated/decelerated in the longitudinal and transverse and vertical directions accordance with the figure below.
 - The impact speed shall be between 30 km/h and 32 km/h.
 - Test weights for use in lockers should be sand bags with masses in kg increments, with a tolerance of +10% - 0%.



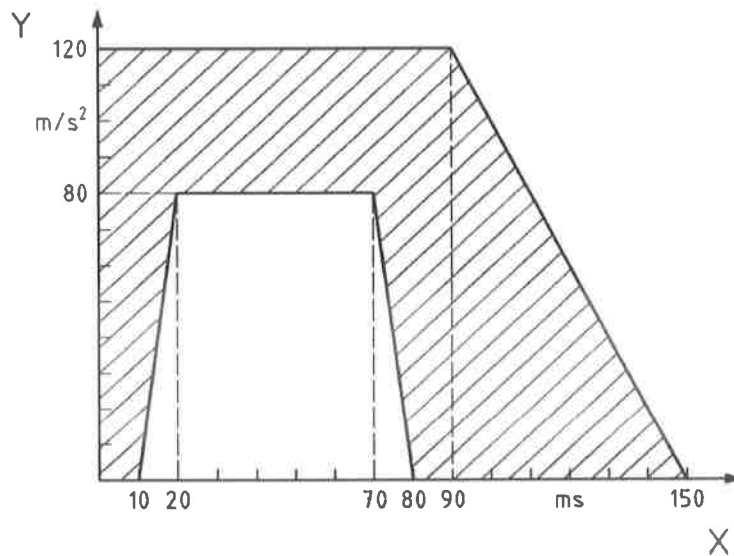

Figure 2: Acceleration impulse

Medical Devices & On-board equipment

- **Medical Devices Storage**

- All equipment required for a set procedure shall be stored in a specified location. Essential equipment required for use outside the vehicle shall be easily accessible via normally used doors. All equipment shall be securely and safely stowed to prevent damage or injury whilst the vehicle is in motion.

- **Requirements for Medical Devices**

- General

- The device shall be designed for use in mobile situations and in field applications. If a medical device is designated as "portable", which is mandatory for use inside a rescue ambulance (except main stretcher, pickup stretcher, vacuum mattress & long spinal board). it shall be in accordance with IEC 60601-1 and shall

- a) be possible to be carried by one person

- b) have its own built in power supply (where relevant)

- c) be capable of use outside the vehicle

- d) be placed preferably along the street side wall of the patient compartment or along the ceiling ensuring the minimum possible distance to be connected to the patient without hindering the movement of personnel around the main stretcher

- Temperature

- Unless otherwise marked on the device, the device shall function as described in the following two points, when



brought back to room temperature (20°C) after storage in temperatures ranging from -30°C to 70°C.

- Unless otherwise marked on the device, the device shall function throughout the temperature range from 0°C to 40°C.
- Unless otherwise marked on the device, the device shall function for at least 20 min when placed in an environment at -5°C after storage at room temperature (20°C).
- Humidity and ingress of liquids
 - Devices shall comply with ISO 60601-1 and with particular device standards of the series ISO 60601-2 where applicable.
- Mechanical strength
 - General: Where there are not more stringent requirements for mechanical strength in particular devices standards exists, then the following mechanical strength requirements shall apply to medical devices for use in road rescue ambulances.
 - Vibration and bump: After vibration tests and bump test in accordance Vibration & Bump test, the maintain system and device shall function within the tolerances specified by the manufacturer.
 - Free fall: If the medical device is fixed, as defined in ISO 60601-1 it is exempted from the free fall test. Devices which are taken out of holders and/or carried by hand shall be submitted to the free fall test according to the Free Fall test (mentioned subsequently) and shall then function within the tolerances specified by the manufacturer. **Note:** A medical device may consist of fixed and loose components, the free fall test applies to the loose components only.
- Fixation of devices
 - The device shall be restrained by means of a fixation system.
 - The fixation system(s), maintain system(s) or storage system(s) shall hold the device to withstand accelerations or decelerations of 10 g longitudinal (forward, backward), 10 g transverse (left, right) and 10 g vertical.
 - Terminal units and electrical socket outlets shall not be used as part of the fixation system.
 - If rails systems are used, they shall comply with ISO 19054. **Note:** Rail systems consist of e.g. rail supports, rails, rail clamps, equipment mount holders, equipment mounts, equipment pin holders and equipment pins.



- Electrical safety
 - All devices shall be selected and mounted so that no harmful influence to the electrical supplies results.
- User interface
 - Buttons, switches, indicators and controls shall be easily accessible and visible. SI units (except for blood pressure and airway pressure) and standardized graphical symbols where applicable shall be used.
- Gas installation
 - All the components should be certified as per ISO/TC 121/SC6 and ISO-15001:2003 as "Compatibility of Medical Equipment with Oxygen"
 - Source of supply
 - a) The source of supply shall consist of one or more of the following, as per the requirement of the source supplies in the different types of road rescue ambulances.
 - i. Gas in cylinders, e.g. Oxygen
 - ii. Any other compressed medical gas as required for treatment and therapy of patients.
 - iii. Vacuum system
 - b) **Note:** All the components of the source of supply should be certified as per ISO:7396.
 - c) All compressed gas cylinders except for sizes up to 2.2 L Water Capacity, must be stored and used in an upright position with the valve end up. Only special compressed gas cylinders designed and certified for use in a horizontal position can be placed in that position.
 - d) The valve of the compressed gas cylinder when is at a height of more than 1500 mm. from the ground level, the cylinder compartment should be provided with an retractable / foldable / flushed / enclosed foot step to permit the user to stand comfortably to access the cylinder valve at the time of changing the cylinders
 - e) The cylinder compartment should have facility to place the regulators safely at the time of replacing empty cylinders and fitting filled ones.
 - f) Rescue ambulances should never be operated with lesser number of cylinders as specified in equipment table.



– System design

- a) The rescue ambulance whenever fitted with a stationary oxygen system, shall have all the essential components and accessories required for two sets of piped oxygen system which shall include as a minimum:
- i. One no. Pressure Regulator for each of the supply sources (stationary as well as portable)
 - ii. Low pressure, electrically conductive, hose approved for medical oxygen.
 - iii. Oxygen piping concealed and not exposed to the elements, securely supported to prevent damage, and be readily accessible for inspection and replacement.
 - iv. Oxygen piped to a self-sealing duplex oxygen outlet station for the primary patient with a minimum flow rate of 100 LPM at the outlet.

In addition to the above, the ambulance shall have hospital type piped medical oxygen system (manifold) capable of storing and supplying medical grade oxygen. The system should comprise of an oxygen cylinder manifold as specified, a cylinder changing wrench, chained and clipped with/within the oxygen cylinder compartment; a pressure regulator; oxygen piping approved for medical oxygen; a duplex oxygen outlet station with quick-disconnect interface for the primary patient and a second duplex oxygen outlet station with quick-disconnect interface for the secondary patient. A medical grade oxygen pressure regulator with inlet filter & static outlet pressure of 4.12 bars / 60 psi shall be provided at the cylinder manifold. It shall include a pressure gauge, an inlet filter, a safety relief valve; a locking mechanism to prevent settings from being inadvertently changed; shall maintain accurate readings and calibrations during ambulance operation and not be affected by the temperature conditions. The manifold should have oxygen cylinders of B or D size only (minimum one D & one B type cylinder / equivalent). An adapter to refill the cylinders from a bulk cylinder should be provided.

- b) The patient cabin shall have a digital display panel for oxygen supply status. The display panel should be certified for use with Medical Oxygen and should have three individual values displayed to constantly indicate the pressure level of both the cylinders as well as the distribution pressure level. The digital displays should show the actual pressure measured by three individual digital pressure sensors as per the pressure level under monitoring (one each for both the cylinders and one for the line pressure).
- 

- c) The changing from one cylinder to the other should not affect the distribution pressure in any way and this change over should occur as fully automatic operation.
 - d) The rescue ambulance shall be supplied with an emergency oxygen outlet for each of the stationary oxygen system available on any of the walls of the patient compartment easily accessible to the patient head end and connected directly at the output of the pressure regulator of the stationary oxygen system ensuring that any fault in the oxygen distribution system would ensure uninterrupted oxygen supply to the patient. The terminal outlets shall be of the same design and operational criteria as the self sealing duplex outlets of the distribution system.
 - e) Outlets shall be adequately marked and identified and not interfere with the suction outlet, whenever provided.
 - f) Stationary oxygen system shall be accessible from outside of the vehicle and shall be physically isolated from the patient as well as the driver compartment
- Gas piping
 - a) Gas piping shall not pass through cupboards and compartments, all ducts for gas installations or gas piping shall be vented.
 - b) The use of remote high pressure lines and gauges are not allowed.
 - Stationary oxygen supply
 - a) The stationary oxygen supply shall comprise a source in accordance with equipment table (under normal temperature and pressure) pressure regulators and terminal units or pressure regulators with flow metering devices. Rescue ambulances should never be operated with lesser number of cylinders as that designated.
 - Portable oxygen supply
 - a) The portable oxygen supply shall comprise a source in accordance with the equipment table (under normal temperature and pressure) and a pressure regulator with flow metering device.
 - Pressure regulators and flow metering devices
 - a) The pressure regulators shall be directly connected to the source of supply and shall comply with the following as applicable:
 - b) ISO 10524-1:2006, Pressure regulators for use with medical gases - Part 1: Pressure regulators and pressure regulators with flow-metering devices.
 - c) ISO 10524-3:2005, Pressure regulators for use with medical gases - Part 3: Pressure regulators integrated with cylinder valves.
 - d) Flow metering devices for connection to terminal units and for



connection to flow-rate control units shall be of dial type without any floats and shall conform to ISO 15002.

– Terminal units

- a) Terminal units shall comply with the requirements of ISO-7396.
- b) The components of terminal unit should be cleaned as defined in "Compatibility of Medical Equipment with Oxygen" as per ISO/TC 121/SC6 and ISO-15001:2003.
- c) The terminal outlet should have an hexagonal geometrical profile to permit only geometrically matching adapters.
- d) The process of inserting the probe into the terminal unit of the distribution system as well as pressure regulators shall be:
 - i. an axial force not exceeding 100N and / or
 - ii. a torque not exceeding 1 N-m
- e) The process of releasing the probe from the terminal outlet should be by
 - i. applying an axial force having torque not more than 1 N-m and not less than 0.1 N-m.
 - ii. applying a push or pull force of not more than 110 N and not less than 20 N.
- f) When all locking provisions have been released, disconnection of the probe from the terminal unit shall require a force of not more than 100 N.
- g) Danger to personnel can occur as a result of the rapid expulsion of probes from terminal units. The design should prevent this from occurring.
- h) The terminal outlets should be colour coded as per ISO-32:1977 colour coding.

– Pneumatic power supply

- a) If the road rescue ambulance is equipped with terminal units, the range of operating pressure shall be
 - i. for compressed medical gases 3.5 ± 0.5 Bar
 - ii. for vacuum ≤ 0.4 Bar absolute pressure and the maximum allowable pressure change between the source of supply and the terminal units shall be
 - iii. for compressed medical gases 10 % at a flow of 40 l/min;
 - iv. for vacuum 20 % at a flow of 25 l/min.



- Additional outlet connectors
 - a) For road rescue ambulances complying with Pneumatic power supply, one additional outlet connector (i.e. a terminal unit or a gas specific connection point) complying with the primary outlet shall be fitted in addition to the outlet connectors necessary for the devices intended to be normally used.
- Test Pressure
 - a) The gas piping shall withstand a pressure of 8 Bar i.e. twice the maximum operating pressure of 4 Bar.
 - b) Note: This pressure is also the maximum pressure supplied by pressure regulators in single fault condition.
- Pin-Index Cylinder Valves
 - a) Pin-index outlet connections of cylinder valves shall comply with IS 3224.
- Flexible Hoses
 - a) Flexible hoses for connecting medical devices to outlet connectors (i.e. terminal units or a gas-specific connection points) shall comply with ISO 5359-2008. If flexible hoses are used between the pressure regulators and the terminal units, the requirements of ISO 11197 apply.
- Alarms
 - a) The alarm level would be as per IEC 60601-1-8-2006.
- Marking and Instructions
 - a) Marking and instructions for use shall comply with Annexure 1 of AIS 125. Operating and maintenance instructions, service records and any other appropriate regulations shall accompany the product.
 - b) Standardized symbols should be used or it should be written in English or any other local language of the area where the equipment is to be used. Usage of any other local languages are not mandatory but is only advised.
- Maintenance
 - a) The manufacturer shall supply instructions for carrying out preventive maintenance.
- **Mechanical Strength - Test Methods for Medical Devices for use in Road Rescue Ambulances**
 - Vibration and bump test - The medical devices shall be submitted to the following tests:
 - Vibration (sinusoidal) according to IEC 60068-2-6, Test Fc



- Frequency range: 10 Hz to 150 Hz
 - Amplitude/acceleration: $\pm 0,15$ mm/2 g
 - Sweep rate: 1 octave/minute
 - Number of sweep cycles: 4 in each axis
 - Random vibration broad-band - reproducibility medium according to IEC 60068-2-64, Test Fh
 - Acceleration Spectral Density 10 Hz to 20 Hz: $0,05$ g²/Hz
 - Acceleration Spectral Density 20 Hz to 150 Hz: $0,05$ g²/Hz, -3 dB/Octave
 - Total RMS acceleration 1,6 grms
 - Duration/axis/mounting: 30 min
 - Bump according to IEC 60068-2-27, Test Ea
 - Peak acceleration: 15 g
 - Acceleration Spectral Density
 - Pulse duration: 6 ms
 - Number of bumps: 1000
 - Direction: vertical, with the medical device in its normal operating position(s)
- Free fall - The medical device shall, while functioning, be submitted to the following test:
- Free fall according to IEC 60068-2-31, Test Ec
 - Height of fall: 0,75 m
 - Number of falls: One on each of the six sides / surfaces of the device

- **List of Equipment**

- Supplementary devices may be introduced depending on local requirements. Where applicable the equipment shall be available across the full age range of patients.
- The minimum mass including a mass reserve required for the listed sanitary, medical and technical devices should be 225 kg.
- The equipment shall comply with the standards mentioned against them if any. Tests conducted by notified international bodies as per the relevant standards shall be acceptable if verifiable certified copies of the test reports and certificates are available.



- All rescue ambulances must be fitted/ carry the following list of equipment with them at all times.

S No.	Equipment	Quantity
1	Main automatic loading stretcher (length 1900 mm - 1970mm, width 530 mm to 570 mm with loading capacity of 150 kg) conforming to EN 1865 standard	2
2	Scoop stretcher (lightweight aluminum stretcher, length 1600 mm - 2000 mm, width - minimum 42 cms, loading capacity - minimum 150 kgs) conforming to EN 1865 standard	2
3	Vacuum mattress (length 1900 mm - 1970 mm, width 530 mm to 570 mm with loading capacity of minimum 150 kg) conforming to EN 1865 standard	2
4	Long spinal board (with head immobilizer & securing straps and plastic material at high strength, should be waterproof & conforming to EN 1865 standard	2
5	Set of fractures/ splints made of mouldable metal or alloy (aluminum) - sizes for both children & adults and for hand & wrist, half arm, full arm, foot and ankle, half leg, full leg (all splints should be washable and reusable)	2 each
6	Cervical collar for both kids & adults (should have pre-molded chin support, locking dials and rear ventilation panel and an enlarged trachea opening, should have high density polyethylene and foam padding, should be X-ray lucent and easy to clean and dis-infect)	4 each
7	KED extrication device	1
8	Stationary oxygen - Minimum 2 Nos. of 10 L water capacity cylinders at maximum 150 kgf/ cm ² filling pressure manufactured as per IS:7285 & certified by chief controller of explosives, Nagpur along with 3/8 bull nose valve as per IS:3224	2
9	Portable oxygen - Minimum 1 Nos. of 10 L water capacity cylinders at maximum 150 kgf/ cm ² filling pressure manufactured as per IS:7285 & certified by chief controller of explosives, Nagpur along with 3/8 bull nose valve as per IS:3224	2
10	Manual resuscitator with oxygen inlet and mask	2

S No.	Equipment	Quantity
11	Airways (nasopharyngeal airways of size 6.5 mm, 7.5 mm, 7 mm, 8.5 mm & 8 mm & oropharyngeal of size 0, 1, 2, 3 & 4)	2 each
12	Electric portable suction aspirator with air flow of at least 30 L/ min and vacuum level of at least 600 mm Hg (ISO 10079-1-1999)	2
13	Manual portable suction aspirator conforming to IS 4533: 1995	3
14	Suction Catheter (12 & 16)	2 each
15	Laryngeal mask airway (for both kids & adults)	2 each
16	Infusion solutions, Litre	4
17	Equipment for injections and infusions set (IV Sets)	2
18	Infusion mounting	2
19	Tourniquet (multiple sizes) conforming to IS 7971:1987	2
20	Automatic External Defibrillator with ability to deliver shock up to 200 joules through biphasic technology; should also consist of an audio alarm	1
21	Nebulizer conforming to IS 9462: 1980	2
22	Manual B.P. Monitor (cuff size: 10 cm - 66 cm)	2
23	Portable Automatic B.P., heart rate & saturation monitor	2
24	Oximeter of ISO 9919 standards	2
25	Stethoscope conforming to IS 3391: 1965	2
26	Thermometer (min: 28 degrees to 42 degrees Celsius)	2
27	Device for blood sugar determination	2
28	Diagnostic Light	2
29	Blanket	2
30	Non woven stretcher sheet	2
31	Kidney bowl	2
32	Vomiting Bag	2
33	Non-glass urine bottle	2
34	Waste bag	2
35	Bed Pan	2
36	Sharps container	2
37	Sterile surgical gloves, pairs	5

S No.	Equipment	Quantity
38	Non-sterile gloves for single use	100
39	Basic protective clothing including high visibility reflective jacket	3
40	Safety/ debris gloves	3
41	Safety shoes	3
42	Safety helmet	3
43	Personal protection equipment against infection including disinfectants	3
44	Fire extinguishers (minimum 2 kgs) complying with IS: 13849 or IS: 2171)	2
45	Hammer	1
46	Shovel	1
47	Hydraulic Cutter/ Spreader	1
48	Warning Triangle Lights	4
49	Spotlight	1
50	Public addressal system	1
51	Two way radio transceiver or better technology for mobile communication with highway surveillance team, tow away crane & control room	1
52	Internal phone within patient compartment for communication with driver	1
53	Automated vehicle tracking system with GPS technology for continuous tracking of vehicle location	1

- List of medicines & dressing material to be carried in rescue ambulance at all times:

S No.	Medicines & Dressing Material	Quantity
1	Band-Aids	20
2	BETADINE SOLUTION 500ml (bottle)	1
3	Cotton roll 500gm	1
4	Crape bandage 15cm x 4mtr	2
5	Crape bandage 7cm x 4 mtr	2
6	DRESSING PAD 10CM X 10CM (pre-sterilized)	10
7	DRESSING PAD 10CM X 20CM(pre-sterilized)	10

S No.	Medicines & Dressing Material	Quantity
8	Elasto plast (dyna plaster) 10cm	2
9	Gauge cloth 80cm x 18 mtr	1
10	Gauge rolls 4 “	1
11	Gauge rolls 6 “	1
12	Plain bandage of various sizes	3
13	HYDROGEN PEROXIDE 400ML (bottle)	1
14	Micropore tape 2”,4”	2
15	SURGICAL SPIRIT BOTTLE 500ML (bottle)	1
16	Glucose 100gm	2
17	I V FLUID DEXTROSE 25% (bottle)	5
18	I V FLUID NORMAL SALINE (bottle)	10
19	I V FLUID RINGER (RL) (bottle)	10
20	I V FLUID 5% GNS (bottle)	5
21	Inj adrenaline 1ml	5
22	Asthalin-neubilizing solution	5
23	Inj atropine 1ml	20
24	Inj avil 2ml	5
25	Budesonide-neubilizing solution	5
26	Inj distilled water 5ml	5
27	Inj dizazepam 2ml	5
28	Inj hydrocortisone 100 mg	5
29	Inj lasix 2ml	5
30	Inj paracetamol 2ml	5
31	Inj rantidine 2ml	5
32	Inj tramadol 2ml	5
33	Inj tranexaminic acid	4
34	Inj neostigmine	4
35	Inj haemaccel	2
36	Inj mannitol	5
37	Inj sodabcarb 7.5%	5
38	Inj metaclopramide	5
39	Inj phenytoin	5
40	Inj hyosymine bromide or dicyclomine hydrochloride	5
41	Inj methargin	5

S No.	Medicines & Dressing Material	Quantity
42	Ors 4.20gm	10
43	SYP ANTACID ANAESTHETIC GEL (bottle)	1
44	SYP PARACITAMOL 60ML (bottle)	1
45	TAB ACTIVATED CHARCOAL (strip)	1
46	TAB CLOPIDOGREL (strip)	1
47	TAB DISPRIN/ASPRIN (strip)	1
48	TAB PARACETAMOL (strip)	1
49	TAB ISOSORBRITE DINITRATE 5MG SUBLINGUAL (strip)	1
50	XYLOCAINE (WOCAINE GEL) 2% 30GM JELLY (tube)	1

Rescue Ambulance Manpower

- **1 trained EMT staff with the following qualifications/ experience**
 - Basic qualification of EMT - Diploma in E.M.T
 - B.Sc. (PCB) with certification in BLS/ ALS/ ACLS/ ITLS (or) B.Sc Nursing/ GNM/ ANM (or) B.Pharma/ D. Pharma or any other equivalent paramedical course from recognized university/institution of IMC/INC
 - Minimum 2 years of relevant experience in first-aid and life saving emergency skills including spinal immobilization, bleeding control, oxygen therapy, defibrillation and medicine administration.
 - At least one training (minimum one month) in tertiary care institution or at a recognized institute with experience in handling life-saving equipment.
 - Basic training in extrication
- **1 Driver**
 - Valid license to drive an rescue ambulance
 - Ability to read/ write & maintain log books
 - Basic training in delivering first aid & victim extrication

Rescue Ambulance Branding & Recognition

- **Recognition and visibility of rescue ambulances**

The Rescue Ambulance Conspicuity Code is split into six Sections.

- i. Colour
- ii. Conspicuity Improving Items (C2I)
- iii. Emblems
- iv. Warning Lights



- v. Sirens
- vi. Recognition of personnel

The Section “colour” describes the vehicles basic colour. The Section “Conspicuity Improving Items” or “C2I” includes all Symbols, Marking and Striping defined as such by this standard. The Section “Emblems” refers to every item that doesn’t fall under the definition of C2I which can be private company signs or corporate identities. The Section “Warning Lights” describes colour, position, alignment, luminosity, photometric brightness, flash patterns and electrical current consumption of all used warning lights. The Section “Sirens” determines the volumes, frequencies and electrical current consumption of all used sirens and speakers.

- **Colour**

- The basic colour of the complete exterior should be brilliant blue as per Annexure-I attached, front, rear and side bumpers included. The colour should be weather resistant and withstand daily cleaning and washing.

- **Conspicuity improving items**

This definition includes all marking and symbols as shown in the figure 3 and 4 below. All C2I-markings should be in brilliant red, RAL- Code 3024 and in retro reflective quality. Conspicuity improving items: “AMBULANCE” markings, the Star of Life and the emergency number symbol. All “AMBULANCE” markings must follow a 7:1 ratio, length to height.

- **Front:** No less than 50% of the front side of the vehicle should be brilliant Blue in contrast to no less of 10% brilliant red. The word “AMBULANCE” on brilliant blue background, minimum of 65% of the hood width, shall be in mirror image (reverse reading) for mirror identification by drivers ahead.
- **Side:** The side of the vehicle should be equipped with a two lined red on the white ground colour as shown in figure 4. The vehicle side should be brilliant blue followed by an “AMBULANCE” marking on the same height. “Star of Life” symbol, with a size of 40cm x 40cm, and the emergency number logo, with a size of 40cm x 75cm. The vertical centre from both of them should match the vertical centre of the side windows of the driver cabin. The words “Basic Life Support” shall be marked respectively just above the word ambulance in size no less than 50% of the size of the word “AMBULANCE”

- **Emblems**

- NHA emblem should be placed in allowed instead of “XXX” in a non-reflecting manner and the size can’t be bigger than 60% of the “AMBULANCE” markings. Ambulance Calling Number 1033 must be

displayed prominently on the side and back of the Road rescue ambulance.

- **Warning lights**

- All warning lights have to be mounted rectangular to the horizontal ground. They must provide 100% of their intensity in a vertical angle of ± 4 degrees and 50% in a vertical angle of ± 8 degrees. The minimum intensity is for blue and red lights at 100cd at daylight and 200cd in the night. The horizontal minimum angle should be at least 45 degrees. All lights must flash between 2Hz and 4Hz and should be mounted as on the graphic below

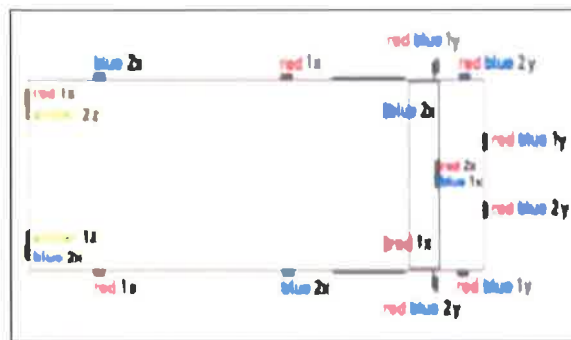

Flash Pattern

1. Indicates light flashing the same time
2. Indicates light flashing
3. 180 degree out of phase with 1
4. 'x' indicates 'ON' lights in primary and secondary mode
5. 'y' indicates 'ON' light only in primary mode
6. 5 'z' indicates 'ON' light only in secondary mode

- Lights marked with “red blue” must show red and blue in one piece one at a time. In daytime they must flash red in nighttime they must flash blue. Two lights have to be mounted in the lower middle windshield only flashing to the outside of the car. All lights should be flashing as shown in the graphic above. To switch from Primary into Secondary Mode there has to be one switch that allows only one mode.

- **Sirens**

- All siren loudspeakers have to be mounted on the front of the vehicle. Hidden installation is allowed. The main sound direction must be in driving direction. Permitted are wail and yelp signals that cycle between 10-18 respectively 150-250 per minute at an sound pressure level of 110dB(A) to 120dB(A). The sirens should be tested in accordance with IS 1884 (though not covered in the standard). The frequency range must be at least one octave and should be between 500Hz and 2.000Hz. An additional electronic air horn can be used. Further there should be a public address system that can be worked

at all times ergonomically from the driver's seat. The siren switch can only be used if the warning lights are on.

- **Recognition of personnel**
 - Safety garments for rescue ambulance personnel should conform to at least ISO 14116:2008.



Figure 3: Rescue Ambulance - Front View

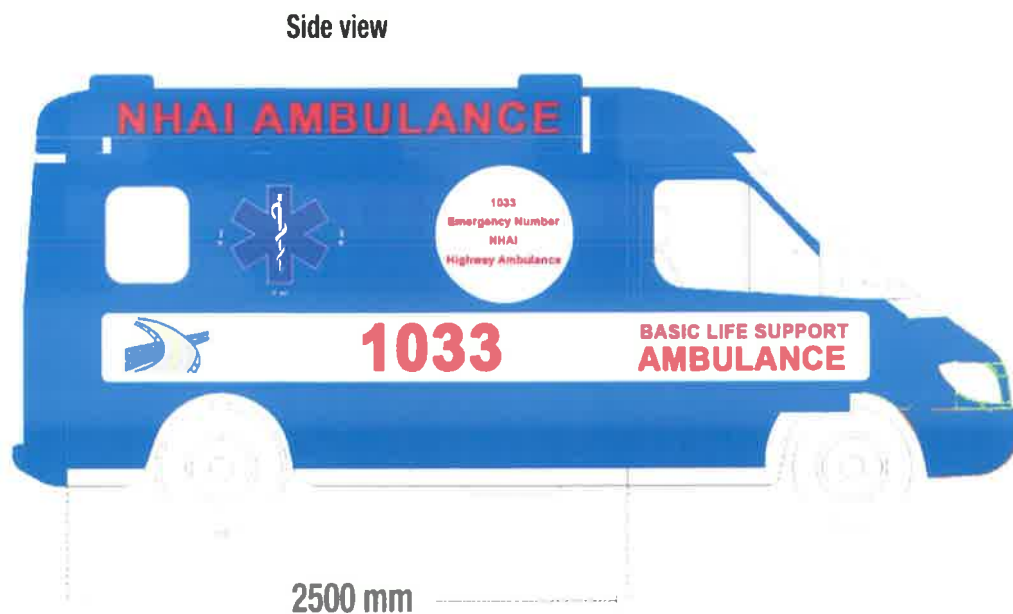

Figure 4: Rescue Ambulance Side View

Brilliant Blue Colour Code : C: 87%, M: 74%, Y: 0%, K: 0%

Patrol Vehicle Specifications

Every Patrol Vehicle (PV) should adhere to the minimum specifications as described below:

General Vehicle

Type	Description
<p>1. Vehicle type</p>	<ul style="list-style-type: none"> • PV should be a large size Sport Utility Vehicle(SUV) or Multi Utility Vehicle(MUV) with a seating capacity of minimum 4 people • PV should have trunk with open ceiling at the rear end of the vehicle with minimum trunk dimensions of 1400mm x 1400mm x 900mm where 1400mm is the length of trunk measured from inside, 1400mm is the breadth of trunk measured from inside and 900 mm is the height measured from the surface of trunk to the top ceiling of the seating area of the vehicle • The PV should be a new vehicle and should not have covered more than 2000 km at the time of procurement (from date of first registration) • PV should be able to accelerate from 0km/ h to 80 km/ h within 20s with a top speed of 80 km/h when tested in accordance with IS: 11851-1986
<p>2. Two-External equipments</p>	<ul style="list-style-type: none"> • PV should have high intensity red and blue blinkers along with light bar mounted on top of a vehicle • PV should have 1 Portable Variable Message Sign(VMS) for large display of warning. The portable VMS Should have a single line display with the minimum height of 200 mm for each character. The overall length of signboard should be atleast 1500mm and display color should be red. VMS should be clearly readable from 50 m distance. • PV should have provision for fog lights • PV should have beacon lighting - white color flashing light mounted at the top of the vehicle
<p>3. Branding and recognition</p>	<p><i>The PV conspicuity code is split into three Sections</i></p> <ul style="list-style-type: none"> ○ Color ○ Conspicuity Improving Items ○ Recognition of personnel <p>The Section "Color" describes the vehicle basic color. The Section "Conspicuity Improving Items" includes all Symbols,</p>



Type	Description
	<p>Marking and Striping defined as such by this standard. The Section "Recognition of personnel" describes the dress code and safety garments of Patrol Vehicle personnel.</p> <ul style="list-style-type: none"> • Color <ul style="list-style-type: none"> - The basic color of the complete exterior of PV should be brilliant blue, front, rear and side bumpers included. The color should be weather resistant and withstand daily cleaning and washing. ○ Conspicuity Improving Items <ul style="list-style-type: none"> ○ This definition includes all marking and symbols as shown in the sketch below. The vehicle should be painted with brilliant blue on the entire body. ○ PV should have "NHAH Highway Surveillance Unit" written on all four sides of the vehicle in brilliant red color of retro reflective quality as shown in figure 5. ○ PV should have a text at the centre of all four sides of the vehicle with "Emergency Number" written on top and "1033" written right below "Emergency Number" in brilliant red color of retro reflective quality. The "Emergency Number" marking should be atleast 10 cm high and the ratio of height of "1033" and "Emergency Number" should be 2:1 ○ Recognition of personnel <ul style="list-style-type: none"> ○ All PV Personnel should wear brilliant blue color uniform including brilliant blue color jackets required in winters ○ Safety garments for PV personnel should conform to at least ISO 14116:2008.

The branding and recognition pattern of PV described above should resemble with the one shown in the sketches below:





Figure 5 : PV - Side View

Equipments

Following are the list of equipments and specification of each to be kept in working condition in every PV

Type	Description
1. Tracking equipments	<ul style="list-style-type: none"> • Automatic vehicle tracking system with GPS technology for tracking vehicle's current location; Information to be viewable on GIS software
2. Communication Equipments	<ul style="list-style-type: none"> • 1 Two- way radio device with antennae or better technology for mobile communication, for communication with Regional Command Center and with on-road units. Should have a sufficient range to communicate in the entire region(or state) & sufficient battery life (12 hours+) • 1 Public address system consisting of microphone, amplifier and loudspeaker to address the traffic in case of accident, should have minimum 100 W amplifier with loud sound • 1 Cellular phone for communication
3. General Surveillance Equipments	<ul style="list-style-type: none"> • 1 Digital Camera with minimum 5 megapixel camera quality • 2 white color high intensity torch lights with two set of spare batteries • 3 Orange color reflective safety jacket along with gum boots and helmet (1 for every attendant)

Type	Description
	<ul style="list-style-type: none"> • 3 Rain suit (1 for every attendant of Surveillance Unit) • 2 units of liquid containers with minimum 5 L capacity for carrying petrol/diesel along with a funnel • 1 water container • 1 rope of minimum 20 m length • 10 orange/red color reflective flags of atleast 300 mm height • 1 whistle • 2 hand signals
<p>4. Vehicle Repairing Equipments</p>	<ul style="list-style-type: none"> • 3 pairs of leather gloves • 2 ton hydraulic jack capable of lifting car, bus and light trucks, should be able to attain a maximum height of atleast 300 mm • 1 Heavy duty steel towing chain of minimum 1.5 m length • 1 Animal hook • 1 Tire gauge with minimum 0-50 psi range and tire sealant • 1 Portable tire inflator pump capable of filling tires upto a pressure of 50 psi; should be able to inflate tires of cars, buses and light trucks • 1 pair of Starter leads with multimeter: For making connections with external power source • 1 Tow bar for towing purposes • 1 Mechanical toolkit with equipment like hammer, fencing pliers, mallet, ratchet wrench set, screwdriver set, battery brush, etc.
<p>5. Extrication & First Aid Equipments</p>	<ul style="list-style-type: none"> • 1 Portable electric windshield cutter operated by battery or external power source, should be able to cut all type of windshields causing minimum glass dust • 1 Hydraulic/electric portable hand cutter and spreader combined tool, should be able to cut off vehicle parts, metal structure, steel plate. Should have maximum cutting force > 250 KN, spreading force ≥ 25KN with opening distance of Blades > 150 mm • 4 wooden wedges, 4 rectangular wooden blocks of minimum dimensions 150 * 120 * 60 mm for stabilizing light and heavy vehicles



Type	Description
	<ul style="list-style-type: none"> • Two struts capable of stabilizing a vehicle of minimum 1500 kg weight • 1 Long spinal board (with head immobilizer & securing straps and plastic material at high strength, should be waterproof & conforming to EN 1865 standard) • 1 Cervical collar for both kids & adults (should have pre-molded chin support, locking dials and rear ventilation panel and an enlarged trachea opening, should have high density polyethylene and foam padding, should be X-ray lucent and easy to clean and dis-infect) • 1 KED extrication device for both kids and adults should be made of polymer/wooden bars in a nylon jacket • 1 Pick-up stretcher conforming to EN 1865 standard (minimum usable length of 1650 mm and extendable to a minimum of 2010 mm, minimum width of 400 mm, mass not more than 11 kilograms & should have minimum loading capacity of 150 kilograms) • 1 First aid kit • 2 woolen blankets • 1 Map locating nearest hospital, police station, fire station
<p>6. Scene Management Equipments</p>	<ul style="list-style-type: none"> • Minimum 10 Reflective cones of 750 mm each, should be orange in color with retro-reflectorised white band and a heavy rubber base with minimum possibility of being displaced by wind/vehicular traffic • 4 kg dry Powder Fire Extinguisher • 3 pairs of Rubber gloves • 1 Hard bristle broom • 1 Shovel • Sign boards with messages <ul style="list-style-type: none"> ○ 3 - "Accident ahead" ○ 3 - "Lane merging"- 3 units ○ 3 - "Direction arrows" - 3 units ○ 2 - "Speed Limit" (80, 60, 40) ○ 2 - "Keep left/right" ○ 2 - "Lane closure" ○ 2 - "Men at work" ○ All signs should be of retro reflective sheeting of High intensity grade or Prismatic grade

Type	Description
	<ul style="list-style-type: none"> • 9 units of Sign stand (for triangular and circular sign) for height between 1.5 m to 2 m • 2 Reflective type barricade, tape • 3 pairs of safety glasses and masks for protection of safety officers from glass debris/ airborne dust. • 10 kg sealed bucket with lime or cement inside

Manpower and Trainings

Type	Description
1. Highway surveillance in-charge	<ul style="list-style-type: none"> • <i>1 Highway surveillance in-charge should be appointed per shift per vehicle</i> • Employee appointed should have minimum 2 years of relevant experience in route patrolling and traffic management. • Employee appointed should be able to read/write and maintain log books. • Employee appointed should undergo trainings including fields such as <ul style="list-style-type: none"> ○ Vehicle use and maintenance ○ Safety policies ○ Radio and communication procedures ○ Public relations/ customer service ○ Defensive driving ○ Public relations/customer service ○ Maintenance of traffic ○ Vehicle recovery procedures ○ Victim extrication procedures ○ Extinguishing vehicles fires ○ Basic first aid training ○ Work side protection ○ Minor vehicle repairs
2. EMT	<ul style="list-style-type: none"> • <i>1 EMT should be appointed per shift per vehicle</i> • Basic qualification of EMT - Diploma in E.M.T. • B.Sc. (PCB) with certification in BLS/ ALS/ ACLS/ ITLS (or) B.Sc Nursing/ GNM/ ANM (or) B.Pharma/ D. Pharma or any other equivalent paramedical course from recognized university/institution of IMC/INC • Employee appointed should have minimum 2 years of relevant experience in first-aid and life saving emergency skills including spinal immobilization, bleeding control,

Type	Description
	<p>oxygen therapy, defibrillation and medicine administration.</p> <ul style="list-style-type: none"> • Employee appointed should undergo atleast one training (with duration of minimum one month) in tertiary care institution or at a recognized institute with experience in handling life-saving equipment. • Basic training of employee should include fields such as <ul style="list-style-type: none"> • Vehicle and equipment use and maintenance • Victim extrication from a crashed/damaged vehicle • Safety policies • Radio and communication procedures • Public relations/customer service
<p>3. Driver/helper</p>	<ul style="list-style-type: none"> • 1 driver/ helper should be appointed per shift per vehicle • Employee appointed should have a valid license to drive a SUV vehicle. • Employee appointed should be able to read/ write & maintain log books. • Basic training of employee should include fields such as <ul style="list-style-type: none"> ○ Vehicle driving along multiple shifts ○ Minor repairing of vehicle ○ Vehicle and equipment use and maintenance ○ Radio and communication ○ Work site protection

